

Parts and Accessories. Installation instructions.

Retrofit - Front Apron Attachments (Carbon) BMW 3 Series Saloon (E90) BMW 3 Series Touring (E91)

Retrofit kit No.: 51 19 0 396 346
 51 19 0 396 348
 51 19 0 403 207
 51 19 0 403 208
 51 19 0 402 974

Installation time

The installation time of approx. 1 hour can vary depending on the condition and equipment of the vehicle.

Important information

These installation instructions are mainly intended for use in the BMW dealership network as well as by authorised BMW Service Centres.

The target group of these installation instructions are technical personnel trained on BMW vehicles with corresponding technical know-how.

All work is to be carried out with the aid of currently valid BMW repair instructions, schematic diagrams, maintenance manuals and working instructions in rational order with the specified tools (special tools) while paying particular attention to valid safety regulations.

In order to avoid unnecessary additional expenditure/costs, if any problems regarding installation, assembly or operation are encountered, after spending a little time on attempting to finding the problem (approx. 0.5 hour), an enquiry, including the vehicle identification number, part number of the installed retrofit kit and a detailed description of the problem, should be sent without delay to Technical Support via the Aftersales Assistance Portal (ASAP).

Do not archive the printout of these Installation Instructions as daily updates are conducted through ASAP!

Pictographs:

 identifies information that draws attention to specific requirements.

◀ identifies the end of an information or warning text.

Subject to technical modifications.

Ordering information

Attachments must be ordered from the same series (see customer information, page 2).

The Betalink adhesive package Part No. 82 69 9 408 866 is not included in the retrofit kit and must be ordered separately.

Required special tools

None

Important customer information - Please hand over to customer

 Information necessary for procuring spare parts. Keep in a safe place in the vehicle. ◀

There are two different series of front apron attachments which differ slightly in appearance. Order part from the same series when replacing only one front apron attachment. Only order the series with part number 51 19 0 396 346/348 when replacing both front apron attachments.

The production serial number ... can be found on the inner side of the front apron attachments.

The first series has the serial numbers 001 to 999.

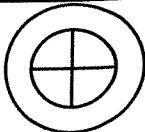
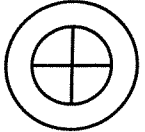
		From 001 to 999, part number 51 19 0 403 207 (left), 51 19 0 403 208 (right)		
Aufsatzteil Frontschürze	Aufsatzteil Frontschürze			
0 403 207	CF-EP		0 403 208	CF-EP
...	200X		...	200X

The second series has the serial numbers from 1000.

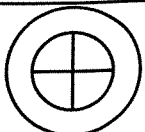
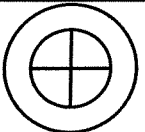
		From 1000, part number 51 19 0 396 348 (left), 51 19 0 396 346 (right)		
Aufsatzteil Frontschürze	Aufsatzteil Frontschürze			
0 396 348	CF-EP		0 396 346	CF-EP
...	200X		...	200X

Enter the serial numbers of the front apron attachments here prior to mounting:

_____ left _____ right

Contents

Section	Page
1. Parts overview	4
2. Preparatory work	5
3. Installation	6
4. Removing attachments	11
5. Finishing off and encoding	13

1. Parts overview

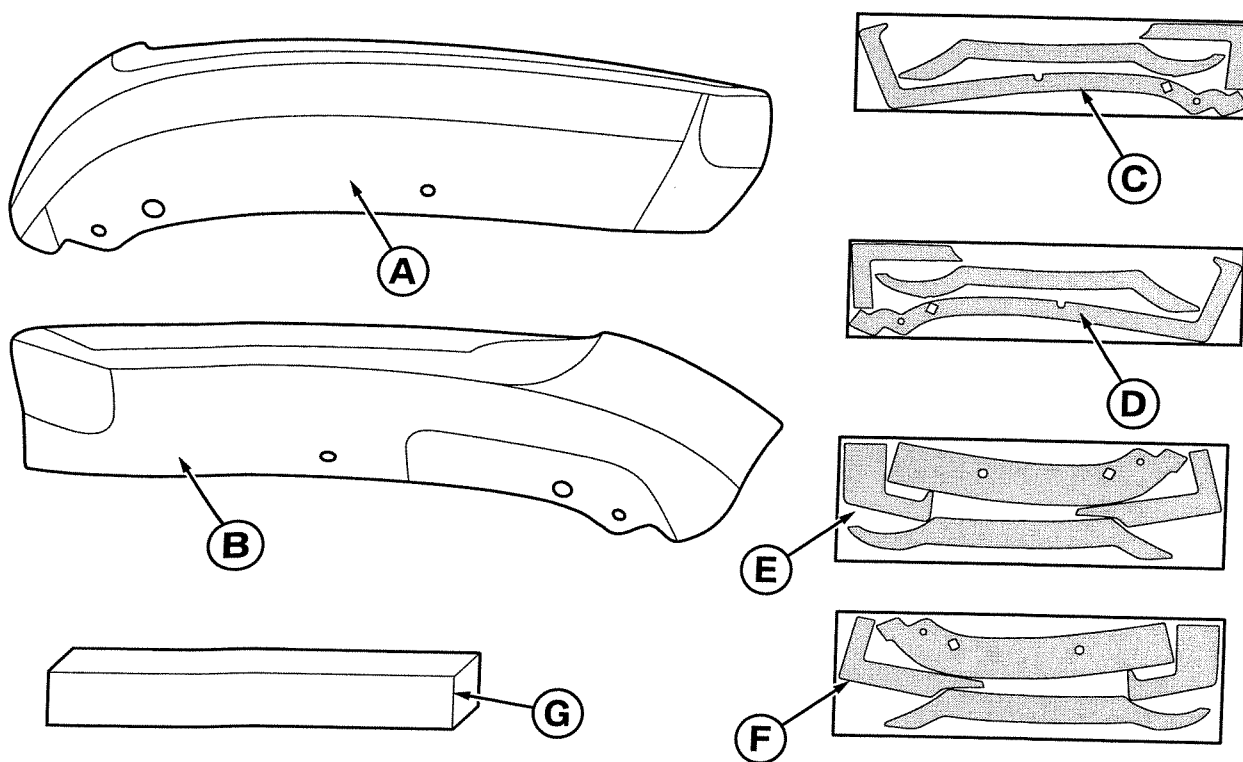

090 0001 V

Key

- A Front apron attachment, right
- B Front apron attachment, left
- C Adhesive punched blank, left (3-piece)
- D Adhesive punched blank, right (3-piece)
- E Adhesive punched blank, right (4-piece)
- F Adhesive punched blank, left (4-piece)
- G Betalink (not included in parts kit)

 Use either the 3-piece or 4-piece adhesive punched blanks when mounting the front apron attachments. ◀

2. Preparatory work

	TIS No.
Remove the following components	
Release underride guard	---

3. Installation

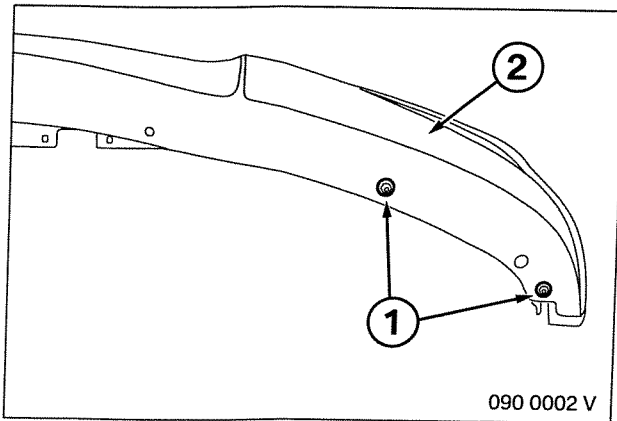

▶ Enter the serial number on the inner side of the front apron attachments in the information for the customer (see Page 2). ◀

Undo screws (1) on front apron (2).

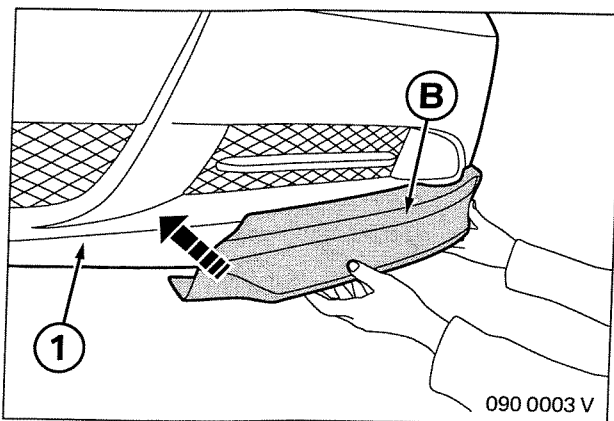

Place front apron attachment **B** on front apron (1).

Mark outline of the attachment on the front apron (1).

▶ It must be possible to completely remove the marks. ◀

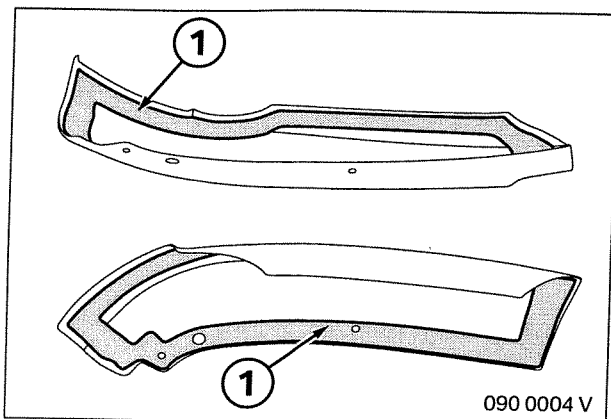

Roughen the inner area (1) of the front apron attachments with abrasive paper from the Beta-link package.

Thoroughly clean area with Betalink primer.

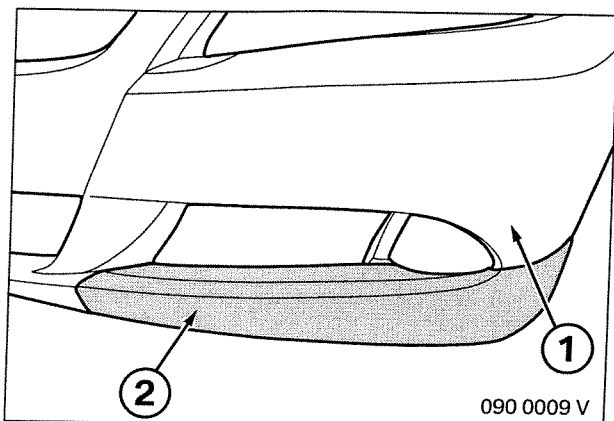

Clean front apron (1) in illustrated area (2) with Betalink primer.

▶ Make sure that the Betalink primer does not come in contact with the fog lights. ◀

3. Installation

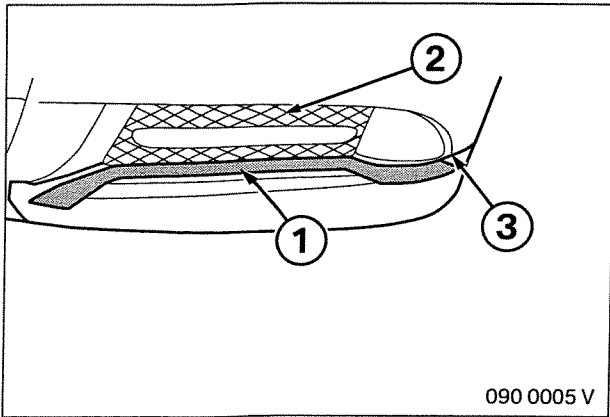

Only for 3-piece adhesive punched blank:

Centre the upper adhesive strip (1) of the adhesive punched blank **C** on the grille (2) and firmly adhere working outwards.

- ☒ Make sure that the adhesive punched blank **C** is secured within the marking (3). ◀

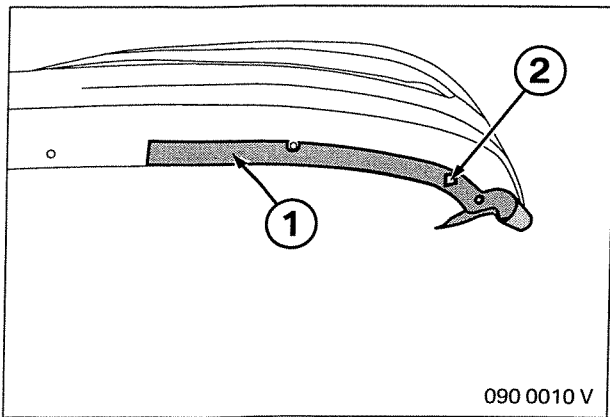

Align the lower adhesive strip (1) of the adhesive punched blank **C** to recess (2) and adhere in position.

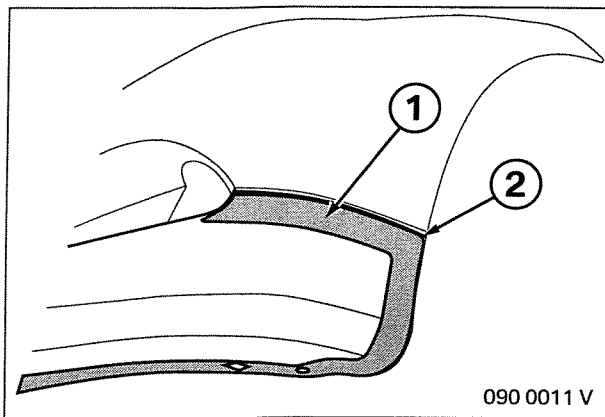

Press down the side part of the lower adhesive strip (1) starting from the bottom, working upwards and inwards.

- ☒ Make sure that the adhesive punched blank **C** is secured within the marking (2). ◀

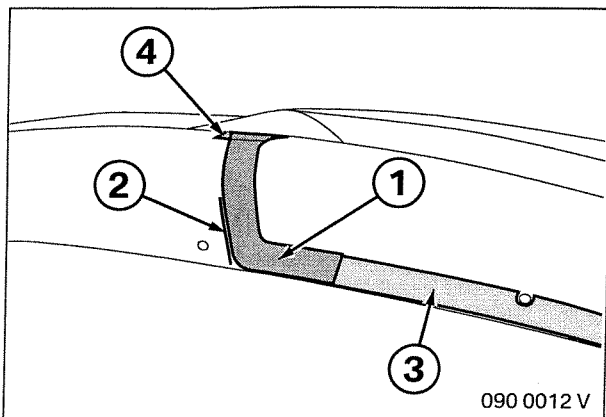

Align the inner adhesive strip (1) of the adhesive punched blank **C** to the marking (2) and press over the lower (3) and upper (4) adhesive strip.

- ☒ Fit front apron attachments **B** in position and check whether the attachment covers all three adhesive strips. Correct position of adhesive strips if necessary.

If necessary use the blade contained in the Beta-link adhesive package to smooth out any bubbles in the adhesive strips (1). ◀

3. Installation

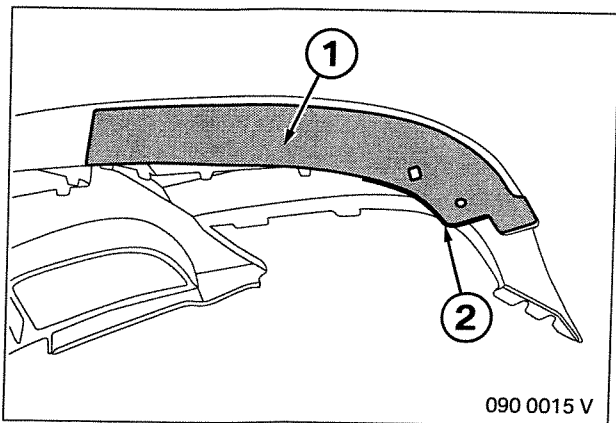

Only for 4-piece adhesive punched blank:

Place adhesive strips (1) of adhesive punched blank **F** aligned with edge (2) and adhere in position.

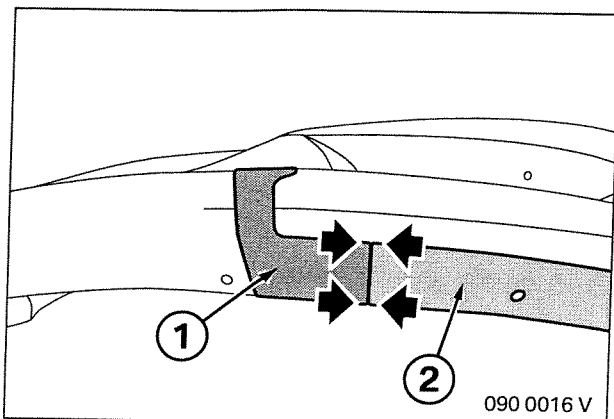

Position inner adhesive strip (1) of adhesive punched blank **F** exactly against the edge of the lower adhesive strip (2) and adhere in position.

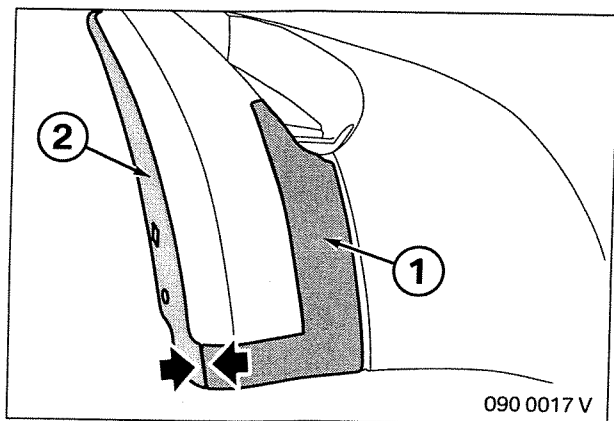

Position outer adhesive strip (1) of adhesive punched blank **F** exactly against the edge of the lower adhesive strip (2) and adhere in position.

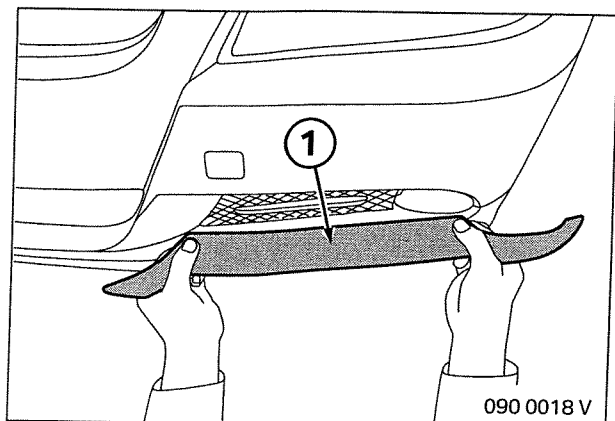

Pull the upper adhesive strip (1) taut by hand.

3. Installation

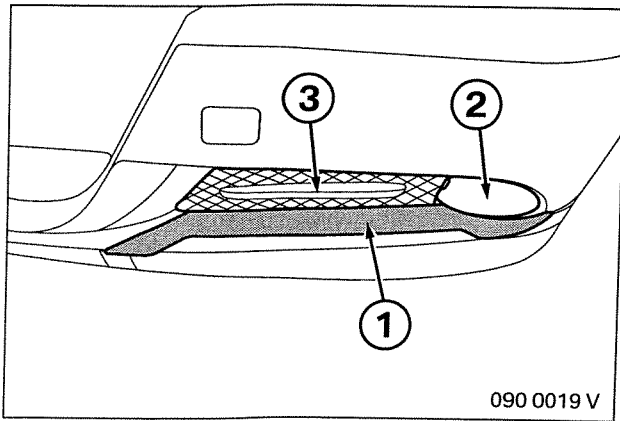

Affix upper adhesive strip (1) of adhesive punched blank **F** aligned with fog light (2) and grille (3). Press down ends over side adhesive strips.

 If necessary use the blade contained in the Betalink adhesive package to smooth out any bubbles in the adhesive strips (1). ◀

Remove the protective film from all adhesive strips (1).

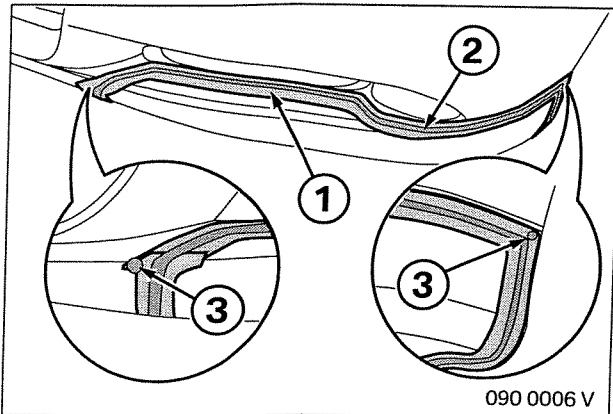

For all adhesive punched blanks:

Clean the adhesive strips (1) with Betalink primer.

Apply a 4 mm diameter bead of Betalink adhesive (2) onto the adhesive strips (1).

Apply spots of adhesive (3) in the corners (magnified view).

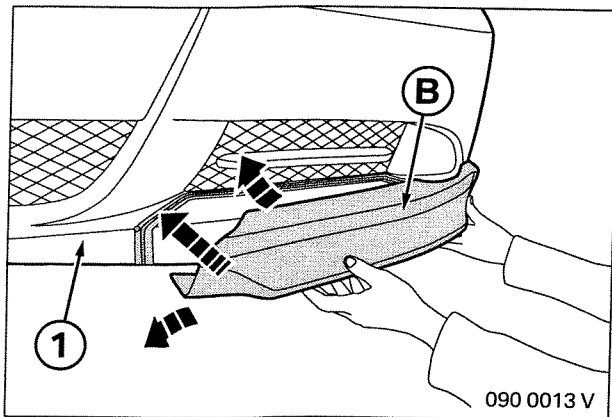

Fit front apron attachment **B** on the wheel arch. Slightly spread apart the front apron attachment **B** and carefully slide onto the front apron (1).

 Remove excess Betalink adhesive with Betalink primer. ◀

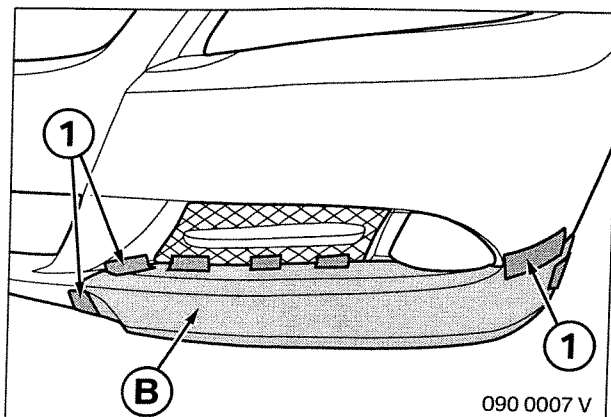

Check the fit of the front apron attachment **B** at all edges and correct if necessary.

Secure front apron attachment **B** with adhesive tape (1).

3. Installation

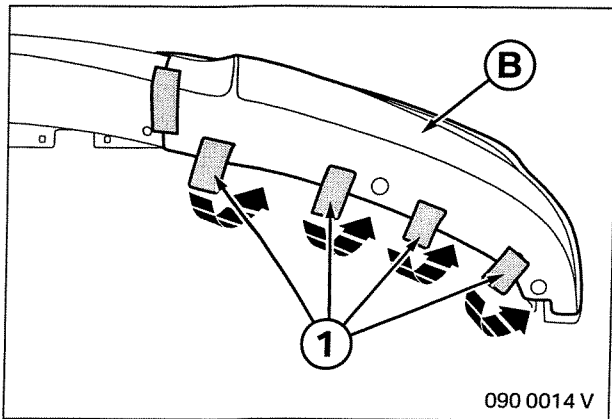

Wrap adhesive tape (1) around lower area of front apron attachment **B**.

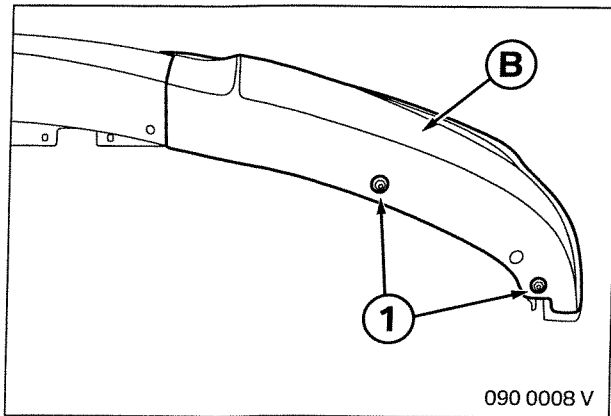

Lightly tighten screws (1) of the front apron.

4. Removing attachments

▶ It is not possible to remove the attachments without destroying them.
Damaged attachments should be removed and replaced by new parts.

Attachments must be ordered from the same series (see customer information, page 2). ◀

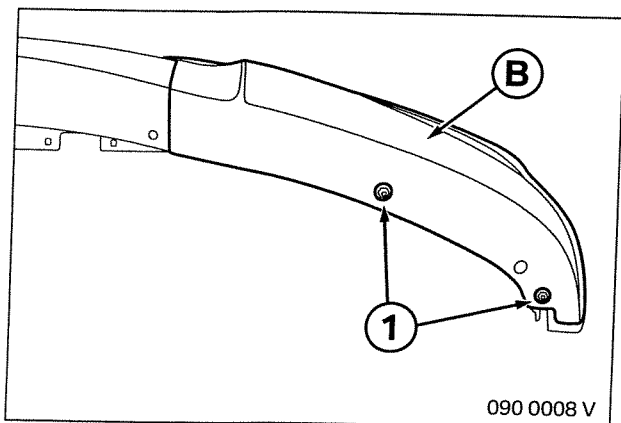

Undo screws (1) on front apron.
Release underide guard.

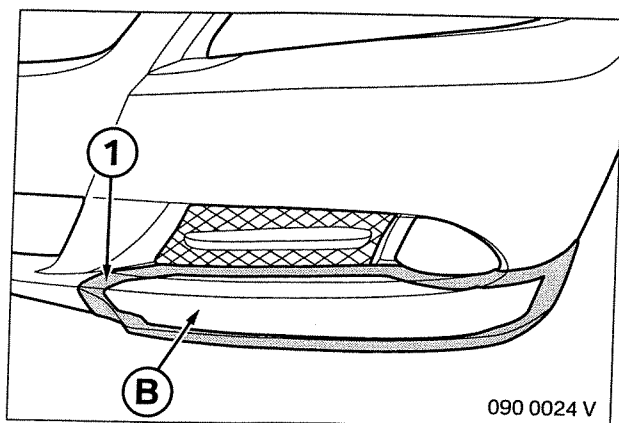

▶ The temperature of the hot-air blower should not exceed 60 °C.

Make sure that the fog lights, grille and painted areas of the front apron are not damaged. ◀

Heat up front apron attachment **B** and front apron in area (1) as illustrated.

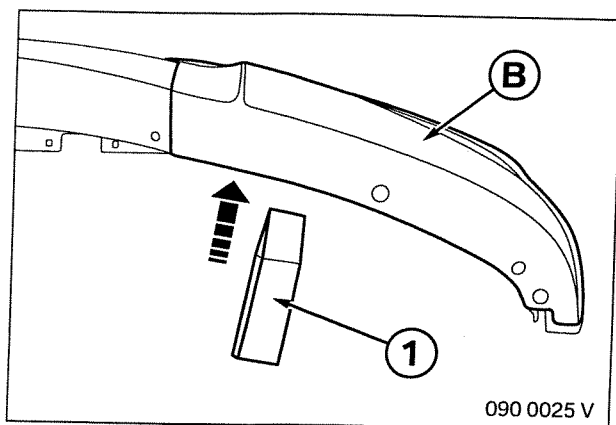

▶ Make sure that the front apron is not damaged. ◀

Use screwdriver or wedge (1) to carefully release the front apron attachment **B**.

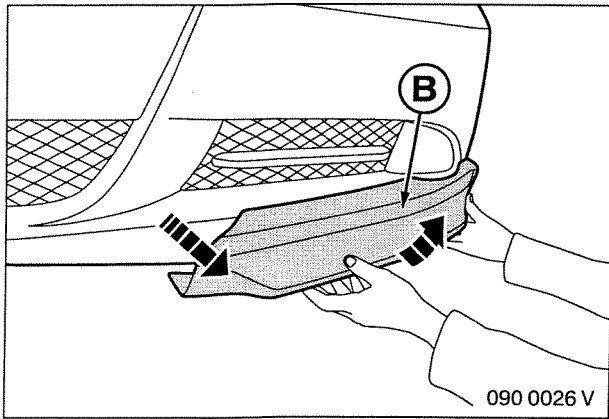

▶ Make sure that the fog lights, grille and painted areas of the front apron are not damaged. ◀

Pull out front apron attachment **B** from below, turn upward and pull or break off.

Use hot-air blower and Betalink primer to remove all adhesive residue.

5. Finishing off and encoding

 The Betalink adhesive requires 6 hours to harden at room temperature. After this period of time, remove the pieces of adhesive tape and screw on underride guard. Completely remove the marks made on the front apron.

The vehicles must not be driven through a car wash for at least 48 hours. ◀

 The customer information (page 2) must be handed over to the customer. ◀